

Radis

Orchestra
Orchestra reference

Integrated amplifier

Owner's Manual

Table of contents

Introduction

Warning

Unpacking and checking

Description

Installation instruction

Tube position

How to match your amplifier to your loudspeaker

How to turn ON your amplifier

Maintenance

Orchestra Specifications

Introduction

At *Jadis*, we are very proud to release a new product after a lengthy period of experimentation and trial.

Our *Jadis* amplifier is therefore the result of long months of technical research and countless hours of listening.

Enjoy your amplifier.

We thank you for your trust in our product.

Warning

Read this document thoroughly before any manipulation. Then read step by step when installing.

Unpacking and checking

The Orchestra integrated amplifier has been packed in a box that has been specially designed for it. Do not throw away this box as it will be needed for re-packing the unit when it has to be returned to the factory for maintenance or upgrading. Please note that the warranty will be considered as cancelled if the unit has been dispatched incorrectly packed.

The boxes should contain: The module block of the orchestra, its tubes, the mains power cable and one 6-sided spanner which is used to remove the covers of the units to allow the tubes to be changed when necessary.

Description Orchestra

Front View

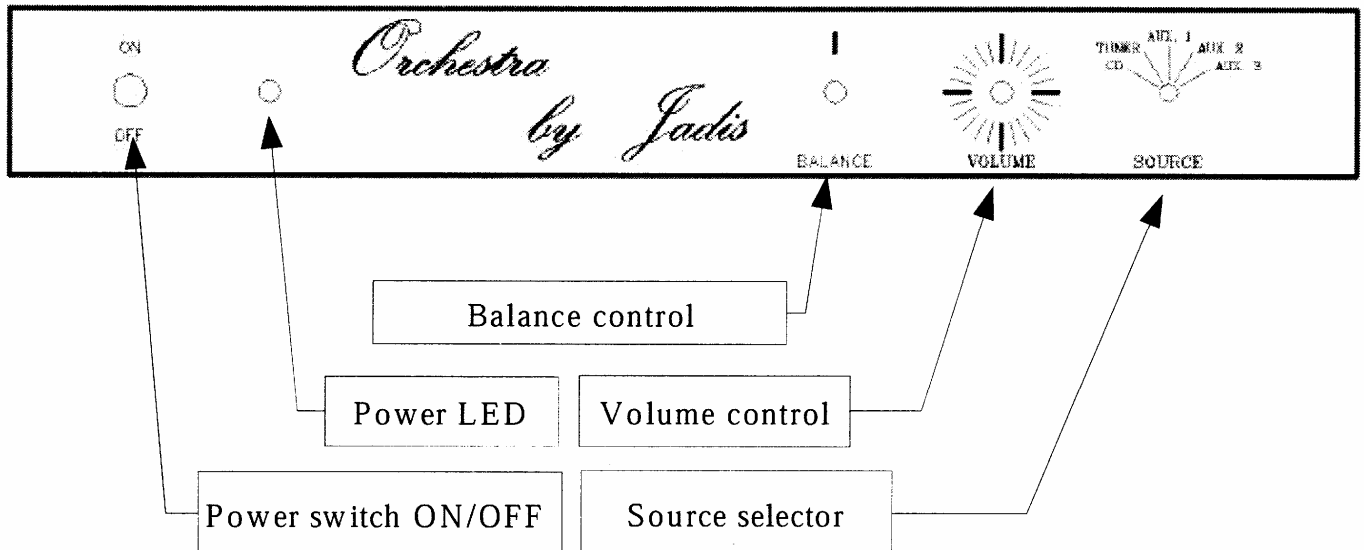

Back View

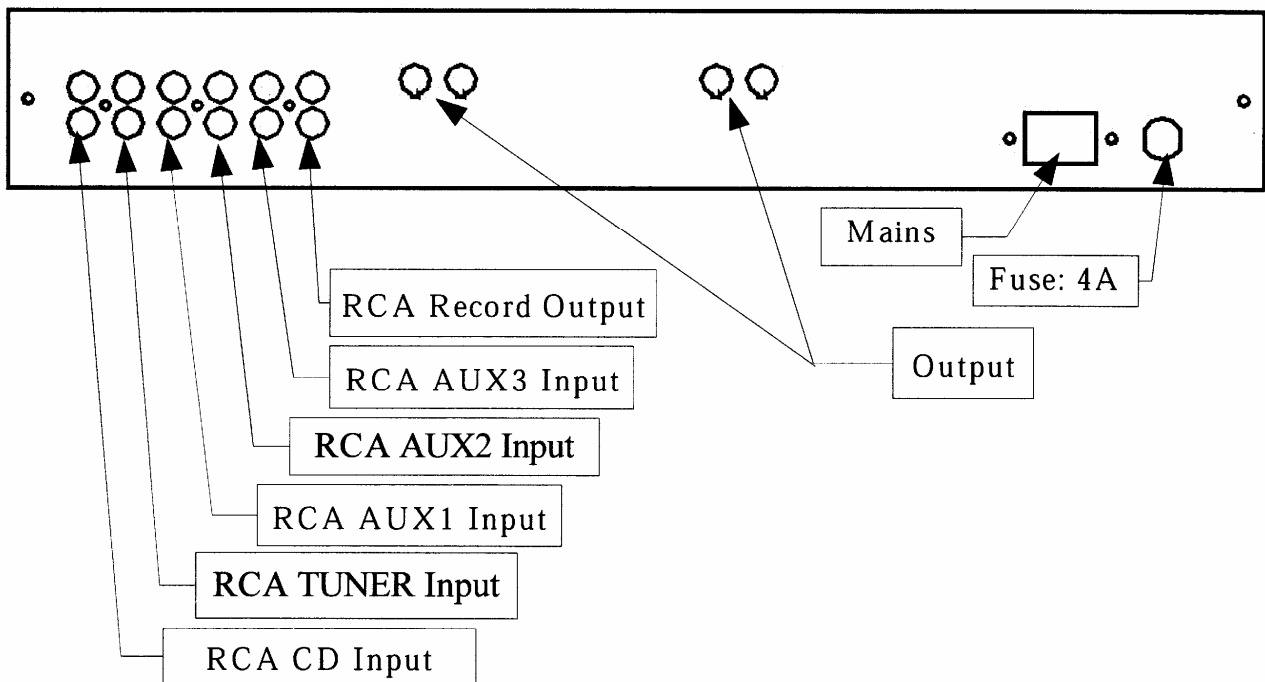

Description Orchestra reference

Front View

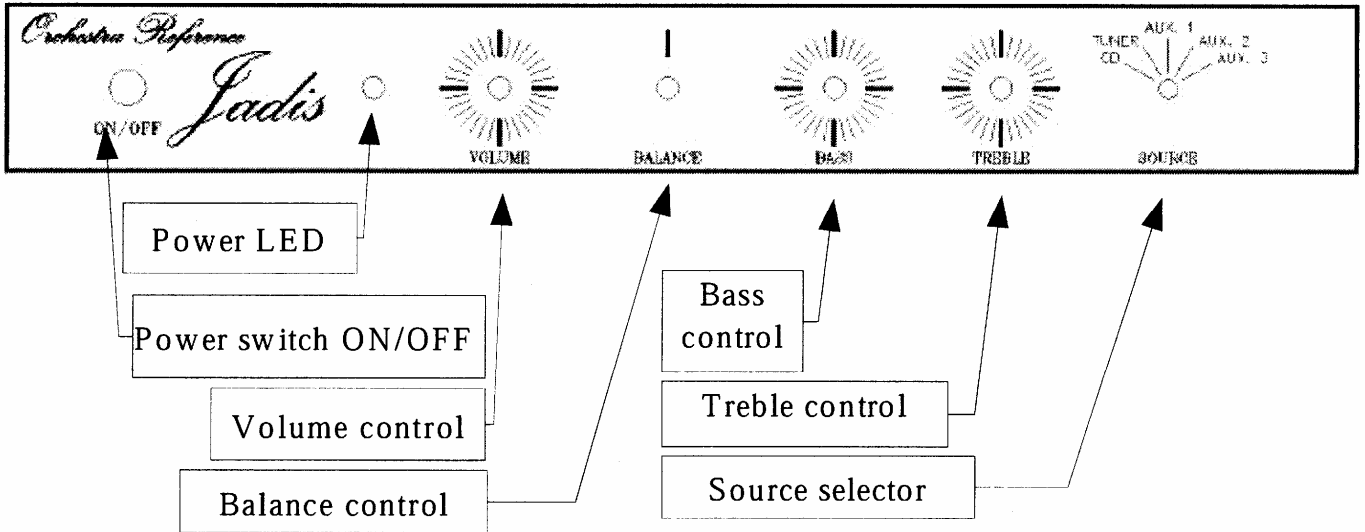

Back View

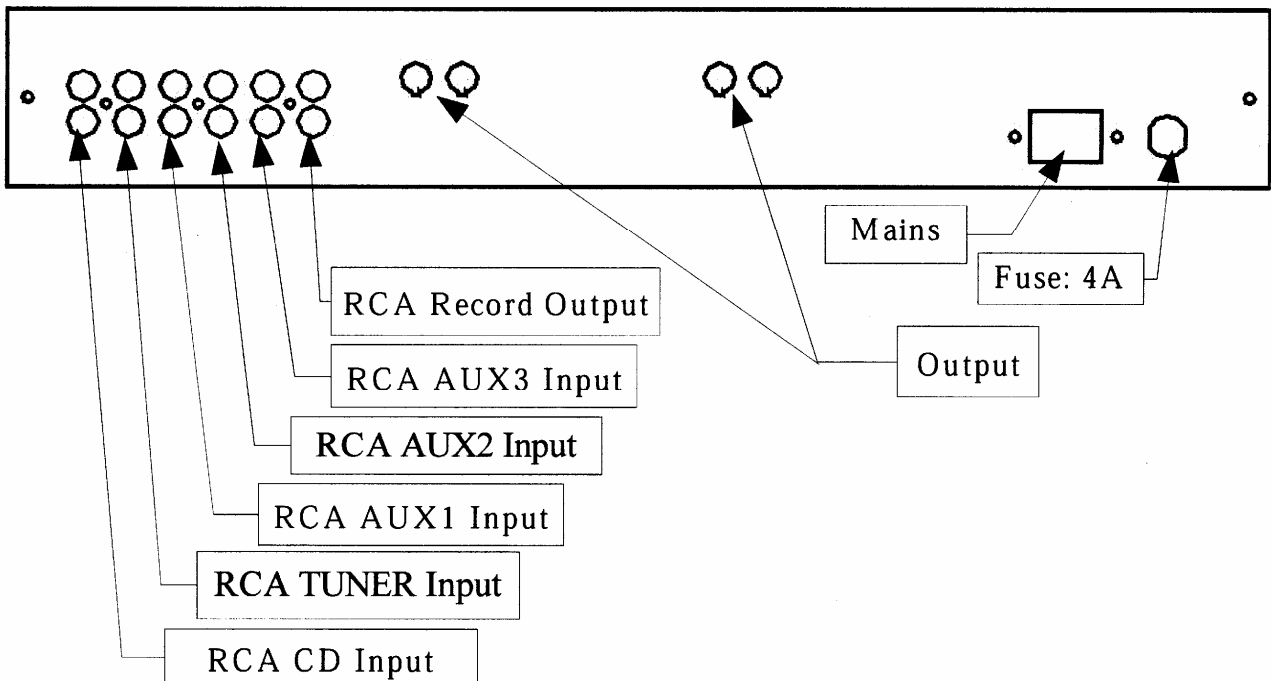

Installation instructions

Read this carefully.

Optimum listening quality is obtained when the following recommendations have been observed step by step.

1 - Each Orchestra is packed with its own tested tubes. Place the tubes: be careful do not mix up the tubes and place them immediately on to their corresponding place as indicated in the « Tube position » page 9.

2 - Place your Jadis amplifier on a flat, solid surface. Avoid placing the units directly on a carpet or on inflammable material. No placing objects on top of the amplifier to ensure adequate ventilation.

3 - Because your Jadis is a tube amplifier, provide an open space to allow a correct evacuation of heat. **Do not try to cool your Jadis amplifier with a fan or expose it to air currents:** sudden cooling can create microcracks on the tubes. Do not move your amplifier when the tubes are hot.

4 - Always turn on your source before turning on the Orchestra. To ensure long term reliability the ON/OFF power switch must be operated with a quick firm movement. Always use the ON/OFF Switch. Never unplug the mains cord to turn off the unit. If it is necessary to change a cable or to modify a connection, make sure the orchestra have been switched off for at least three minutes before proceeding.

Tube position

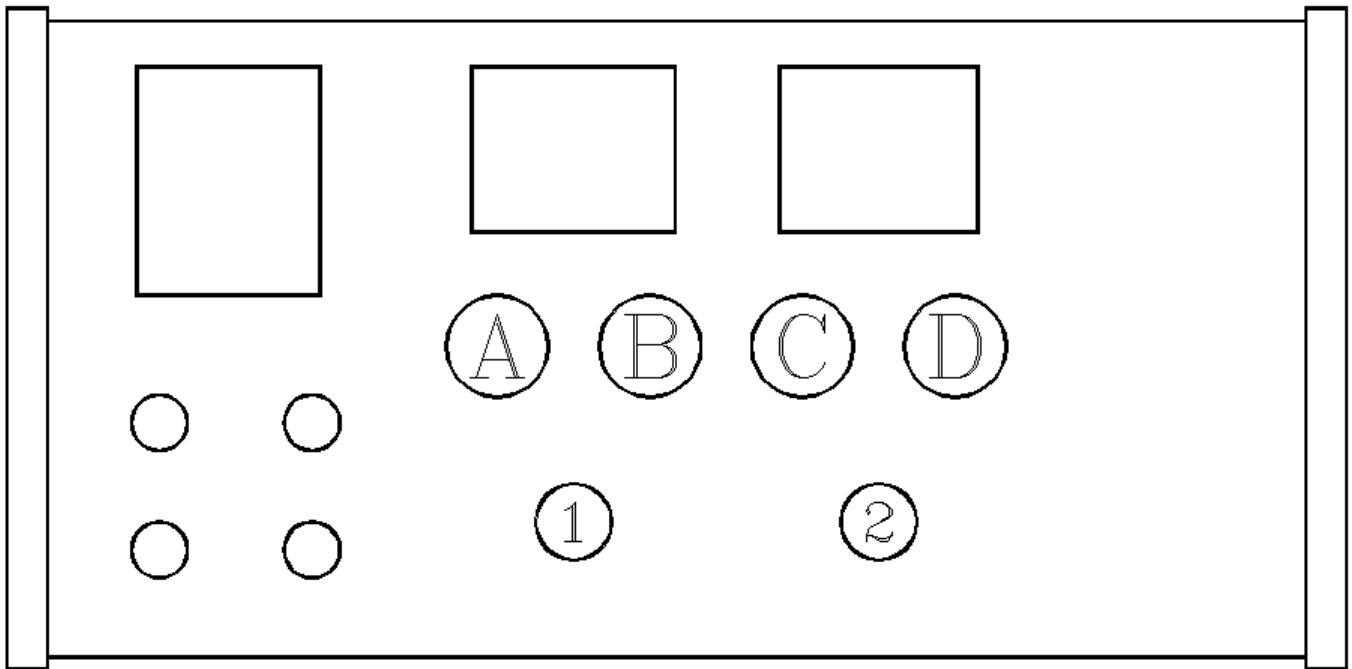

First of all, remove the grid which protects the tube sockets (be sure the mains connector is unplugged).

Warning: For mounting the tubes, do not force them, this may damage the sockets. Be careful at dressing power tubes because they have stop pins on the central parts of the mounting base. Every tube replacement causes an in-built adjustment modification that must be made by a skilled technician. You must use tubes that provide from your distributor.

Mount first the two driver tubes then mount the power tubes . The tubes placement is shown at the top of this page.

Replace the grid and never remove it when the amplifier is connected to the mains voltage, whether it is running or not.

How to turn ON your amplifier

In order to get the best performance from your Jadis amplifier, it is necessary to follow carefully the instructions below:

1- Check that the power switch is set to OFF.

2 - Connect the loudspeaker wires to the red and black terminals at the back of the amplifier.

3 - Connect the interconnect cables between the sources and the amplifier input RCA connectors.

4 - Connect the mains cord of your amplifier which is detachable to facilitate safer and easier moving of the unit. Always use the power cord supplied or one of equivalent electrical rating. Insert the power cord into its socket on the unit before plugging the other end to the mains network.

Your Jadis amplifier is now ready to operate. However, its optimum sound quality will be reached only when the amplifier reaches its ideal temperature (after about 1 hour of operation).

Maintenance

Your Jadis amplifier is adjusted for a nominal voltage corresponding to your country's electrical network.

If the amplifier fails to operate:

- 1 - Turn OFF the unit immediately.
- 2 - Unplug all the cables.
- 3 - Do not forget the mains cord.
- 4 - Contact your Jadis dealer for diagnostic and repair.

To clean your amplifier, use a soft cloth with a non abrasive cleaning product.

Do not forget to unplug all connectors before cleaning.

Orchestra specifications

Load impedance:	1 to 16 Ohms
Output Power at 1kHz:	40 Watts rms / channel
Bandwidth at -3 dB:	5 Hz to 60 kHz
Sensitivity for nominal output power:	250 mV rms
Input impedance:	> 100k Ohms
Maximum power consumption:	300 W
Dimensions:	53 x 27 x 20 cm
Weight:	20 kg

Subject to modification.